

## DESIGN, CONSTRUCTION AND STUDY OF PERFORMANCE OF A FLAT-PLATE SOLAR DETOXIFICATION AIDED HEATER FOR WINTER AIR CONDITIONING OF A SMALL RESIDENTIAL BUILDING IN BANGLADESH

Adib Bin Rashid<sup>1,\*</sup>

<sup>1</sup>Mechanical Engineering Department, Military Institute of Science & Technology  
Mirpur Cantonment, Dhaka-1216, Bangladesh

<sup>1,\*</sup>adib8809@gmail.com

**Abstract-** Rising costs of conventional fuels, increasing energy demand, concerns over climate change and pollutants resulted from burning fossil fuels have increased the interest in various renewable energy technologies. The energy demand associated with heated air for different sectors is quite significant. The Solar Air Heating (SAH) System can be able to replace the conventional power in space heating. In hilly, remote and rural areas, where the power grid extension is limited and fuel shortages & road inaccessibility causes major problems in providing the basic energy needs to these areas, solar air heating systems could be a comparable application for space heating. This paper presents design, construction and technical evaluation of solar air heating system on a small residential building in Bangladesh for winter air conditioning. Also a Solar detoxification reactor technology has implemented with the SAH for the treatment of contaminated re-circulated air.

**Keywords:** Renewable Energy, Solar Air Heater, Space Heating, Winter Air Conditioning, Solar Detoxification

### 1. INTRODUCTION

Conventional solar air heaters mainly consist of panels, insulated hot air duct and air blowers in active systems, without having blower in the passive system. The panel consists of an absorber plate and one or two transparent covers to allow solar radiation to penetrate into the collector. The plate of SAH (usually painted with the black color to maximize absorption) absorbs the solar radiation, and then transfers the heat to a fluid. The working fluid flows through the SAH over the plate, thereby collecting the heat absorbed by the plate via convection.

SAHs are cheap and extensively used. It has wide range of application such as delivering heated air at low to moderate temperatures for space heating, drying agricultural products (i.e., fruits, seeds and vegetables), and in some industrial applications [1].

SAHs are environmentally friendly, i.e., pollution free, sustainable, financially competitive, and safe (flammability and explosively). The SAHs have different advantages compared to water solar collectors such as SAHs are free of freezing, corrosion, or leakage problems. Typical flat plate collectors can obtain outlet fluid temperatures of around 70 °C. The thermal efficiency of these collectors depends on the working fluid, but simple flat plate solar heaters can have efficiencies of about 60% for solar water heaters (SWHs), and about 40% for SAHs for normal operating conditions [2].

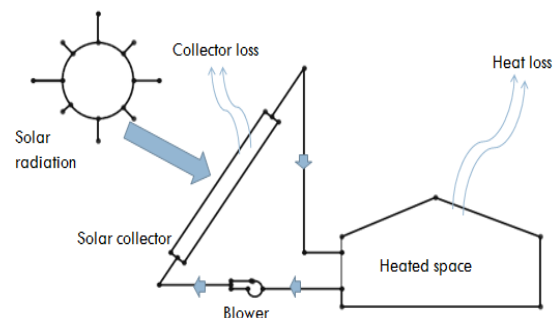

Fig.1: System diagram of air heater

As the sun is a major energy source throughout the ages, technological advances in several fields of science and engineering now make it possible to accelerate the use of solar energy to meet the world's expanding energy requirement. As a consequence of growing concern about the future of the world energy resources, building designers are constantly urged to re-consider their attitudes to the consumption of energy in buildings. With this regard this paper shows a systematic design of SAH with recycling of the same air which leads to generation of harmful bacteria and contamination of air.

## 2. MATHEMATICAL MODEL FOR PERFORMANCE PREDICTION

Fig. 2 shows the schematic diagram of a solar air heater. [4] The heat balance on the air heater gives the distribution of incident solar radiation  $I$  into useful heat gain  $Q$  and the heat loss  $Q_L$ . The useful heat gain or heat collection rate can be expressed as

$$Q = AI(\tau\alpha) - Q_L = A [I(\tau\alpha) - U_L (T_p - T_a)] \quad (1)$$

Where  $A$  is the area of the absorber plate,  $(\tau\alpha)$  is the transmittance-absorptance product of the glass cover absorber plate combination. The heat loss  $Q_L$  from the collector is a sum of the losses from top  $Q_t$ , back  $Q_b$  and edge  $Q_e$  of the collector as depicted in Fig. 2.

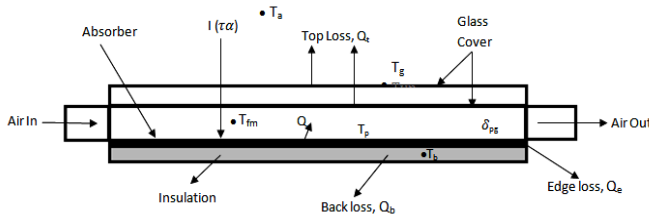

Fig.2: Heat Balance on a solar air heater

The factor  $U_L$  in (1) is termed as overall loss coefficient and is defined as

$$U_L = \frac{Q_L}{[A(T_p - T_a)]} \quad (2)$$

Where  $T_p$  is the mean absorber plate temperature and  $T_a$  is the ambient temperature.

The collected heat is transferred to the air flowing through the air heater duct. Thus,

$$Q = m c_p (T_o - T_i) = G A c_p (T_o - T_i) \quad (3)$$

Where  $m$  is the air flow rate through the collector duct and  $G (= m/A)$  is flow rate of air per unit area of the absorber plate.

Here  $A = WL$  is the absorber plate area. The Reynolds number of the flowing air in the duct is calculated from

$$R_e = \frac{G_1 D_h}{\mu} \quad (4)$$

Where  $G_1 = m/(WH)$  is mass velocity of air in the duct and  $D_h = 4WH/[2(W + H)]$  is the hydraulic diameter of the duct.

Thermal efficiency  $\eta$  of the collector is ratio of useful heat gain to the incident solar radiation on the collector aperture area  $A_a$

$$\eta = \frac{Q}{A_a I} \quad (5)$$

The heat transfer coefficient has been calculated from

$$h = \frac{Q}{[A(T_p - T_m)]} \quad (6)$$

where  $T_p$  is mean plate temperature calculated as the weighted average of temperature readings noted at various points along the axial length of the absorber plate; that is,

$$T_p = \left(\frac{1}{A}\right) \sum (T_i A_i) \quad (7)$$

In (6),  $T_m$  is the mean air temperature taken as arithmetic mean of the measured inlet and outlet air temperature values

$$T_m = \frac{T_i + T_o}{2} \quad (8)$$

## 3. DESIGN OF SOLAR AIR HEATING SYSTEM

The design of a solar air heating systems for a particular application requires the trade off study between efficiency, fan power requirement, desired operation temperature, array size, air ducting and total air volume to be handled. The detail design consideration for solar air collector is illustrated as below: The design can be broken into its components for the sake of analysis. The identification of the possible material and selection of the components which best meet the requirements play an important role. The components taken for the evaluation were Absorber plate, Absorber coating, Glazing and insulation.

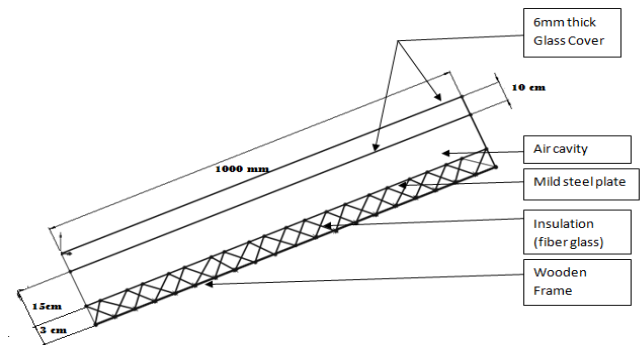

Fig.3: Design concept of SAH

### 3.1 Absorber plate

The solar radiation incident on the absorber plate and raises its temperature. This thermal energy is transferred to the working fluid. The design requirements for the absorber plate taken into consideration are operating temperature range, maximum stagnant temperature, operating flow rate and cost etc. Considerable research has been done on absorber plate materials and their properties. The most common plate materials are metals like copper, aluminum and iron. Among these, copper is the best material due to its thermal conductivity which is 0.18 w/m C, specific heat 0909 cal/gm °C and it is highly resistant to corrosion. Its melting point and boiling points are 1083 °C and 2380 °C respectively. In this research 22 gauge mild steel sheet is used as its cost is very less. Mild steel has conductivity which is 66 w/m K, specific heat 500 j/kgK and it is highly resistant to corrosion. Its melting point and boiling points are 1800 K and 3100 K respectively.

### 3.2 Absorber coating

A surface coating (generally black) is placed on the absorber plate to maximize the absorption of solar energy. The quality of the coating should be such that it absorbs maximum energy and emits the minimum. An ordinary blackened surface absorbs maximum solar radiation but its emittance is also high. Thus, it is not suitable for high temperature applications. For efficient solar air collectors selective coating technique is used for absorber coating.

### 3.3 Glazing or cover plate

The primary function of the cover plate or glazing is to minimize the heat losses from the collector plate, which occur due to convection and radiation. The cover plate must have the following properties:

High transmittance in for solar radiation visible range (low refraction).

Low transmittance for thermal radiation ranges (high refraction).

Low absorptance at all wave lengths. Excellent weather ability and durability.

A number of transparent materials can be used for cover plate. Glass is more frequently used than plastic, or any other material. Though it is very brittle, it is resistant to most alkalis and chemicals. It has uniform transmittance of 90% and absorptance 6% in visible part and is virtually opaque in the infrared range. The glass used in this system has Thermal conductivity 1.7 W/mK, Density 1000 kg/m<sup>3</sup> and Specific heat of 910 kJ/kgK .

The optical properties of glass used in this SAH are given below:

Table 1: Optical properties of glass

	Spectrum type	Incident	Diffused
Absorptance, ( $\alpha$ )	Visible	0.09	0.1
	Infrared	0.09	
Transmittance, ( $\tau$ )	Visible	0.83	0.75
	Infrared	0.83	
Reflectance, ( $r$ )	Visible	0.08	0.84
	Infrared	0.08	

### 3.4 Insulation

Insulation is an important factor playing a very significant role in minimizing the heat losses from the lower surface of the collector plate and from the lateral edges of the collector. If insulation is provided, then heat losses become the function of thermal conductivity of the insulating material and its thickness. The good design requirement for an insulation material in a collector include low thermal conductivity, no degradation, no out gassing or fuming at high temperatures of approximately 200 C and due to repeated thermal cycling up to 150C and being hydrophobic. Glass wool or rock wool can be used for this

purpose. For Insulation Fiber glass has used and it has Thermal conductivity 0.04 W/mK, Density 0.025x10<sup>3</sup> kg/m<sup>3</sup> and Specific heat of 0.67 kJ/kg K

### 3.5 Bottom, Side Frame

The body of the solar panel generally made by aluminum for its low weight, high strength and durability. Aluminum also increases the aesthetic look of the panel. The assembly of aluminum frame is also very easy. But as its cost is high, wood is more preferable for research work on solar panel. Here kerosene wood is used for its cheapness and durability whose thermal conductivity is 100 W/mK, Density 1350 kg/m<sup>3</sup> and Specific heat of 300 kJ/kg K .

### 3.6 Blower

For the distribution of air in the conditioned space a blower of Pressure 55mm (water), 1400 RPM, Frequency 50Hz, air velocity of 12 m/s and air capacity of 0.4 m<sup>3</sup>/s is used.

Table 2: Specifications of solar air heating collectors

Sl. No.	Components	Specification
1.	Size Glazing Absorber	1.5 m <sup>2</sup> double Glazing : 6mm
2.	Plate Absorber	1.5 m <sup>2</sup> Sheet metal (Iron)
3.	Absorber Coating	Selective Coating
4.	Insulation	Fiber glass
5.	Bottom ,Side Frame	Wood (kerosene)
6.	Sealant	Neoprene Silicon base sealant
7.	Duct Connector at either both ends.	Male / Female type at one /both ends coupling with Gasket / sealant for increasing collector size

## 4. EXPERIMENTAL DETAIL

The overall dimension for solar air collector is 1550X1050X300 mm<sup>3</sup> with 6 mm thick glass plate which is placed at around 126 mm from the top side of the collector. The black painted absorber plate of 1500 mm length, 1000 mm wide and 2 mm in thickness. Inlet and outlets of solar air collector is of circular cross section with diameter of 130 mm.

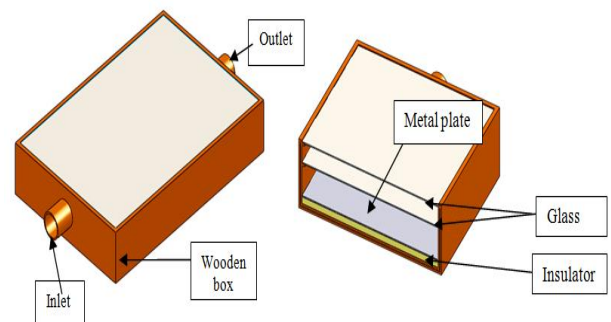

Fig.4. Cad model of the solar air heater

For the distribution of air in the conditioned space a blower of Pressure 55mm (water), 1400 RPM, Frequency 50Hz, air velocity of 12 m/s and air capacity of 0.4 m<sup>3</sup>/s is used. A

double glazing system is used to minimize the heat losses from the collector plate, which occur due to convection and radiation. The experimental work was performed beside the middle workshop, Mechanical & Chemical Engineering Department, Islamic University of Technology under Gazipur prevailing weather conditions during the summer months August and September. Data were collected on an hour interval from 9.00 am to 5.00 pm. As the ground was flat, the collector was proposed to be tilted with  $23.5^\circ\text{C}$ . Generally, the sky in Gazipur was clear all through the month of May to August with cloudy or partially cloudy from time to time. To observe an accurate reflection of the SAH performance, the data which was collected during more consistent weather condition was studied and considered. However some days were ignored in the analysis because of the weather conditions. The instantaneous value i.e. average mean value of the wind speed and relative humidity ratio was taken from the city office was hourly recorded.

The outlet,  $T_{\text{out}}$ , and the inlet,  $T_{\text{in}}$ , temperatures were measured by using T- type thermocouples and the global solar radiation incident on an inclined surface was measured by using a Pyranometer.

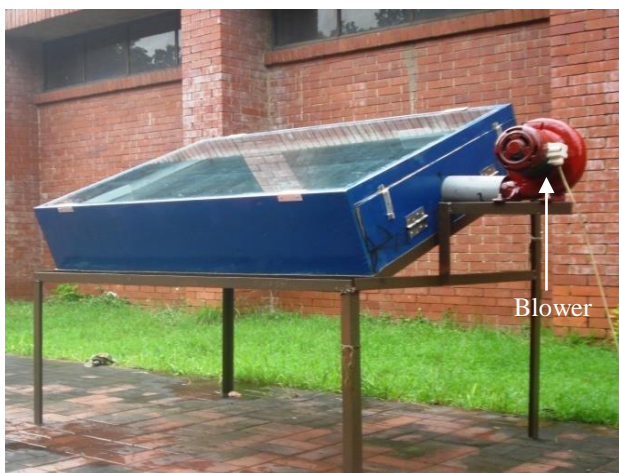

Fig.5: Experimental set up of solar air heater

### 5. RESULT AND DISCUSSION

At the lowest flow rate of the study, the experimental value of the thermal efficiency is lower due to a comparatively higher average wind velocity during experimentation at this flow rate, while the reverse is true at the highest flow rate of the study. Further, it is worth to note that, in general, the ambient temperature has been seen to rise with time (9 am to 5 pm) while the solar insolation increased up to the noon and then decreased. Thus, a transient condition exists, and the efficiency values increased. Hence, looking to the effect of variation in the experimental conditions, the experimental and predicted values can be regarded to be in good agreement, and the presented model can be used to predict the performance of the solar air heater under a wide range of ambient (solar insolation, wind velocity, and ambient temperature) and air mass flow rate conditions. The absorber plate emissivity  $\epsilon_p$  has been assumed to be 0.95, long wave emissivity of glass  $\epsilon_g$  as 0.88, and transmittance-absorptance product  $\tau\alpha$  as 0.8. The scatter in

the experimental data is due to the variation in the ambient conditions. The theoretical analysis shows that the variation in the wind velocity has greater effect as compared to the variation in the ambient temperature and solar insolation in the experimental range of these parameters.

Table 3: Experimental results

Time Hrs	Solar Intensity ( $\text{W}/\text{m}^2$ )	Ambient Temp ( $^\circ\text{C}$ ) Obtained by Expt	Outlet Temp ( $^\circ\text{C}$ ) obtained by Expt	Efficiency $\eta$ (%)
9 am	621.7	32.5	41.3	57
10 am	750.5	34.7	43.6	48
11 am	879.5	35	46.1	51
12	909	35.9	48	54
1 pm	948	36.5	49.8	56
2 pm	909.5	36.3	48.7	55
3 pm	790	34	47.2	67
4 pm	737.5	32	45.3	72
5 pm	656	30	43.1	76

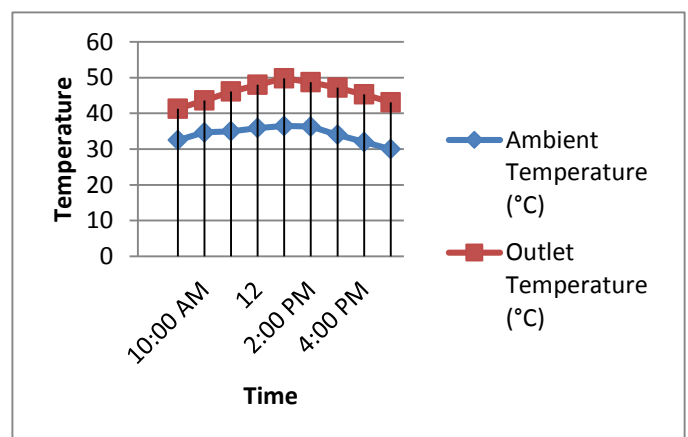

Fig.6: Temperature Vs Time graph

### 6. TREATMENT OF CONTAMINATED AIR IN SOLAR AIR HEATING SYSTEM

The solar air heating systems installed for space heating used to recycle the same air which leads to generation of harmful bacteria and contamination of air. The solar detoxification can be the solution for this problem. The solar detoxification is process of treatment of contaminated air, in which titanium dioxide ( $\text{TiO}_2$ ) is exposed to the sun, the catalyst absorbs the high energy photons light from the UV portion of the solar spectrum and reactive chemicals known as hydroxyl radicals are formed. These radicals are responsible for disinfection of contaminated air. The solar detoxification process treats air at room temperature, roughly 20 to 40 degree C.

### 7. CONCLUSION

Development of these technologies has reached a point where the solar technology can be competitive; with the conventional technologies. The solar detoxification reactor suggested in this paper shall be able to treat the contaminated air in solar air heating systems. Solar air

heating systems could be a useful and environmental friendly technology for space heating in hilly, remote and rural areas, where the power grid extension is limited and fuel shortages & road inaccessibility causes major problems in providing the basic energy needs to these areas. The Experiments show that there is temperature rise of maximum 15° C and maximum efficiency is 76%.

### 8. REFERENCES

- [1] Tyagi, S.K., Shengwei Wang, M.K. Singhal, Kaushik S.C, Parkd, S.R. 2007. Exergy analysis and parametric study of concentrating type solar collectors. *International Journal of Thermal Sciences*. 46, 1304-1310.
- [2] Shanmugam, V. and Natarajan, E. 2007. Experimental study of regenerative desiccant integrated solar dryer with and without reflective mirror. *Applied Thermal Engineering* 27,1543-1551.
- [3] Prasad,S.B., Saini, J. S., Singh Krishna, M., 2009. Investigation of heat transfer and friction characteristics of packed bed solar air heater using wire mesh as packing material. *Solar Energy* 83, 773-783.
- [4] B. K.Maheshwari, Rajendra Karwa, and S. K. Gharai, Performance Study of Solar Air Heater Having Absorber Plate with Half-Perforated Baffles, *International Scholarly Research Network, ISRN Renewable Energy*, Volume 2011, Article ID 634025, 13 pages,doi:10.5402/2011/634025
- [5] Sopian, Supranto, M.Y. Othman, W.R.W. Daud, B.Yatim. 2007, Double-pass solar collectors with porous media suitable for higher-temperature solar- Assisted Drying systems; *Jurnal of energy Engineering* 13, 9402 133 -1 13.
- [6] Yeh,H.M.,Ho,C.D. 2009. Solar air heaters with external recycle. *Applied Thermal Engineering* 29, 1694-1701
- [7] Romdhane, ben salma, 2007.The air solar collectors: Comparative study, Introduction of baffles to favor the heat transfer. *Solar Energy*, 139-149.
- [8] Garg,H.P. and Adhikari R.S., 1999. Performance Evaluation of a single solar air heater with N-Subcollectors Connected in Different combination. *Int. J. Energy Res.*, 23, 403-414
- [9] Suleyman Karsli, 2006. Performance analysis of new-design solar air collectors for drying applications. *Renewable Energy* 32 , 1645-1660.
- [10] Turgut, O. and Onur, N, "Three dimensional numerical and experimental study of forced convection heat transfer on solar collector surface", *International Communications in Heat and Mass Transfer*, vol. 36, 2009, pp. 274-279.